



SPRING MOUNTS (RCA or RCB Series)

RCA or **RCB** series spring mounts are unboxed laterally stable steel springs contained in molded neoprene acoustical cups (weld free construction) with leveling bolt assembly. These spring mounts can be supplied with a base plate if required to be bolted to floor.

These spring mounts are recommended where horizontal and vertical stability is required. These series spring mounts are used for vibration and noise control applications such as pumps, centrifugal fans, air handling units, air compressors and similar applications.

RCA – 100 Series

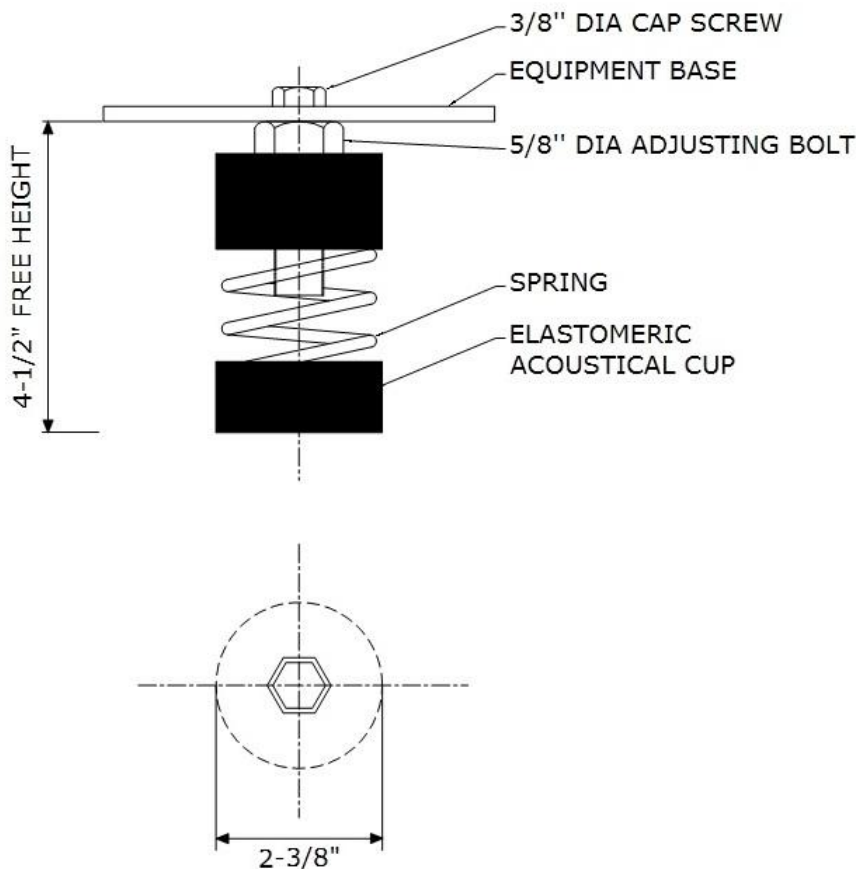

NOTES:

Spring: Hot Dip Galvanized

Drawing with dimension details of the RCB Series Spring Mounts and RCA isolator model information is listed on the following page.



RCB – 100 Series

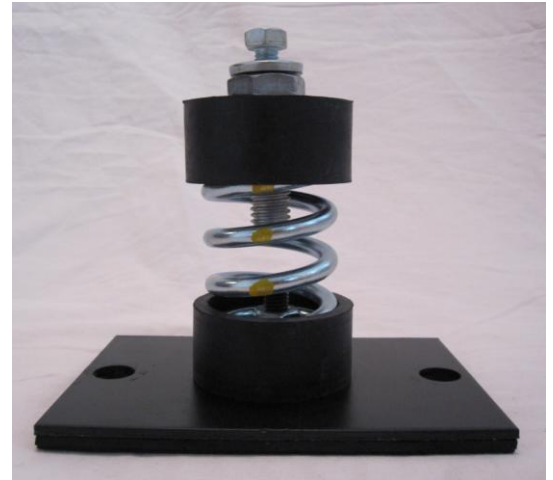
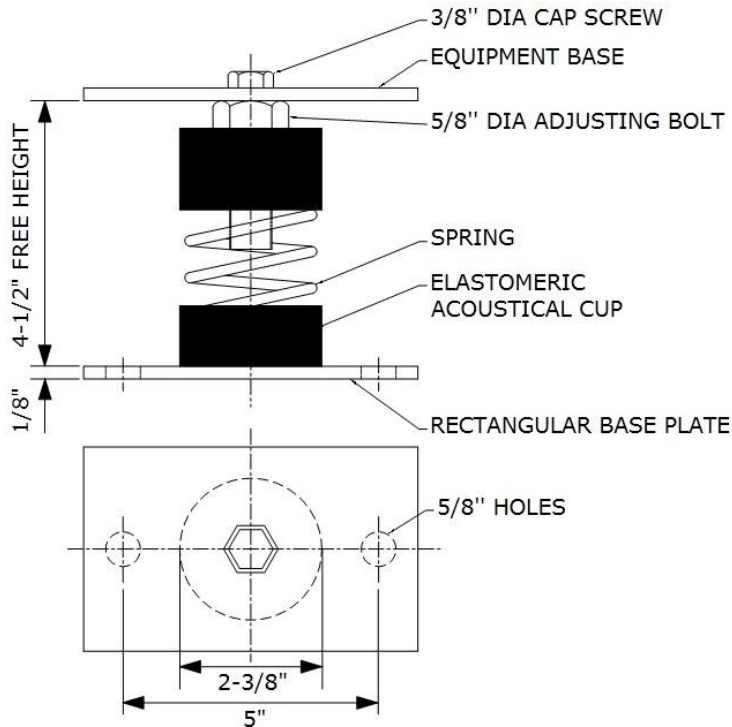

NOTES:

- Spring: Hot Dip Galvanized
- Base Plate has non-skid Acoustical Neoprene Pad

ISOLATOR MODEL*	RATED LOAD (LBS)	RATED DEFLECTION (INCH)	COLOR	
			MAIN	STRIPE
RCA-101	60	1.3	SILVER	BLUE
RCA-102	100	1.3	SILVER	ORANGE
RCA-103	165	1.2	SILVER	BROWN
RCA-104	260	1.0	SILVER	BLACK
RCA-105	370	0.8	SILVER	YELLOW
RCA-106	450	0.5	SILVER	RED
RCA-107	700	0.45	SILVER	GREEN

* For isolator with base plate, please quote model RCB, instead of RCA